

GHR-...-7750

GIUNTI ROTANTI PER OLIO IDRAULICO
ROTATING JOINTS FOR HYDRAULIC OIL
DREHDURCHFÜHRUNGEN FÜR HYDRAULIKÖL
RACCORDS TOURNANTS POUR HUILE HYDRAULIQUE
JUNTAS ROTATIVAS PARA ACEITE HIDRAULICO

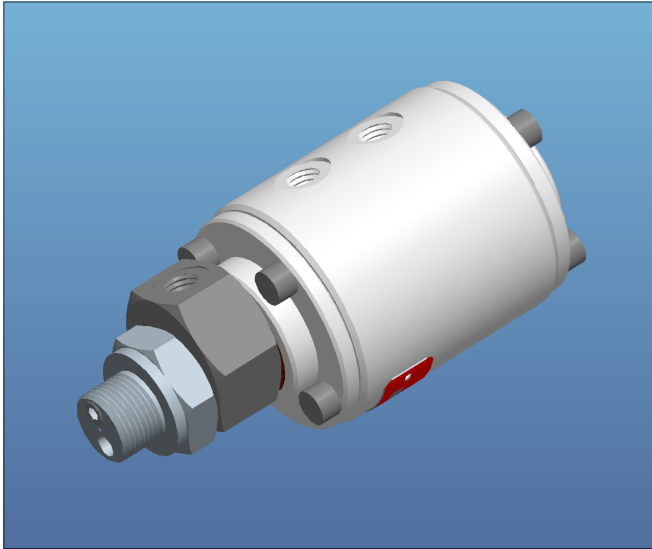

t_{max}	90 °C	p_{max}	1 ÷ 250 bar
n_{max}	2500 min⁻¹	Filtration	10 µm

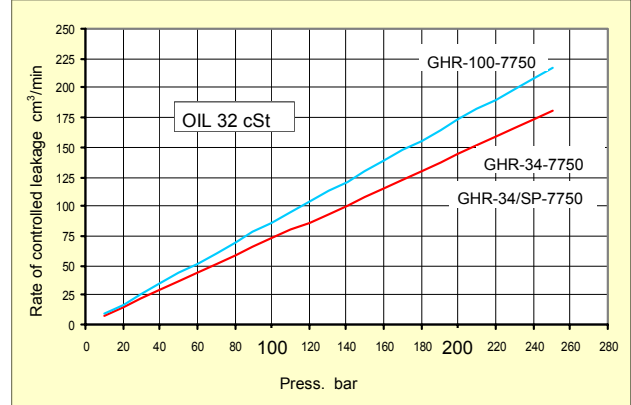

Giunto due vie con trafileamento controllato drenato attraverso connessione DR
 Two passage joint with controlled oil leakage drained of at connection DR
 Zweikanal Drehdurchführung mit kontrollierter Leckage: aus Anschluß DR
 Raccord tournant double passage avec drainage contrôlé: par connexion DR
 Junta rotativa doble paso con drenaje controlado: por salida DR

Evitare l'impiego alla massima velocità con la massima pressione.
 Avoid working at maximum speed with maximum pressure.
 Max.Drehzahl gleichzeitig mit max. Druck ist zu vermeiden.
 Evitez l'emploi de la pression maximum à la vitesse maximum.
 Evitar el trabajo a máxima velocidad combinada con máxima presión.

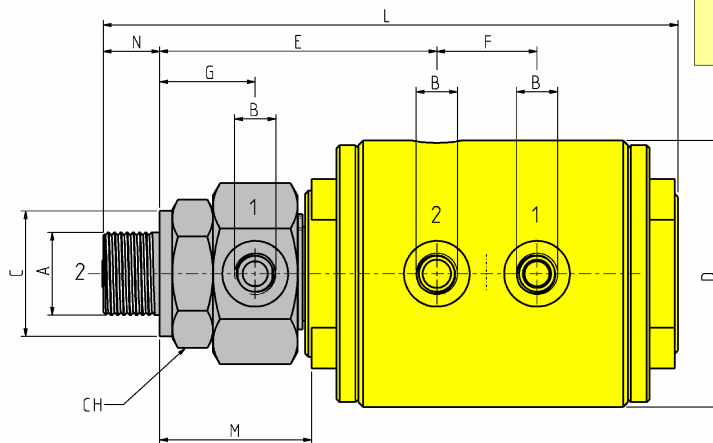

ROTAZIONE A SECCO NON POSSIBILE
METTERE OLIO IN CIASCUNA VIA PRIMA DI RUOTARE

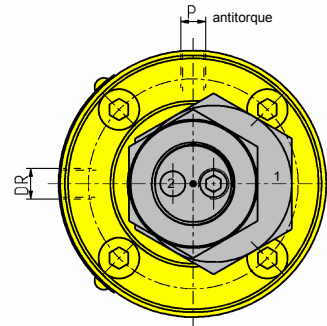

DRY RUN NOT POSSIBLE
 FILL OIL INTO BOTH PASSAGES BEFORE STARTING TO ROTATE

KEIN TROCKENLAUF
 VOR INBETRIEBNAHME BEIDE KANÄLE MIT ÖL BEFÜLLEN

PAS DE ROTATION Á SEC
 REMPLIR CHAQUE PASSAGE AVEC HUILE AVANT UTILISATION

ROTACIÓN EN SECO NO POSIBLE
 LLENAR AMBOS PASOS CON ACEITE ANTES DE ROTAR

TIPO TYPE MODELL	A BSP	B BSP	C f7	D	E	F	G	L	M	N	P	DR BSP	Ch	PESO- WEIGHT Kg
GHR-34-7750	3/4	1/4	40	85	88.5	32	30.5	183.5	46	18	M8	1/8	41	2.0
GHR-34/SP-7750	1"	1/4	40	85	88.5	32	30.5	183.5	46	18	M8	1/8	41	2.0
GHR-100-7750	1"	3/8	40	95	98.5	36	35	200	55.5	20	M8	1/8	41	2.2
GHR-114-7750														
GHR-112-7750														

TURIAN

Via Jucker,19
 I-21053 CASTELLANZA (Va)

tel. ++39 0331 501101
 fax ++39 0331 505189